

中心距数显卡尺

151系列

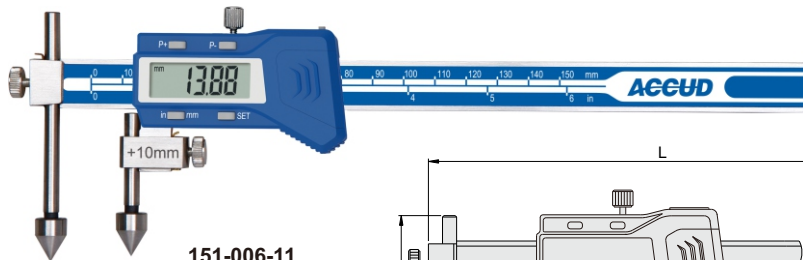

操作视频



151-006-11

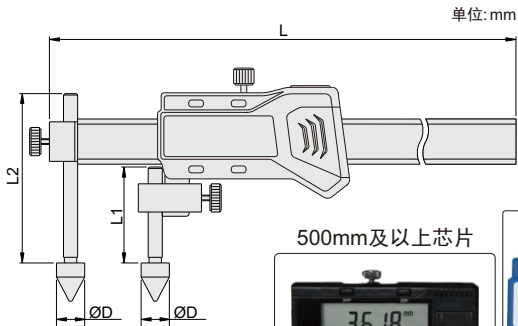

- ◆ 用于测量处于相同或不同平面的两个孔中心的距离
- ◆ 分辨率: 0.01mm/0.0005"
- ◆ 按键: 公/英制转换, 设置数值, 数值预置(P+,P-)
- ◆ 滑动开机, 自动关机
- ◆ 带数据输出
- ◆ 不锈钢尺身

预置按键

500mm及以上芯片

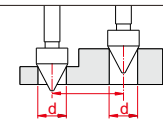
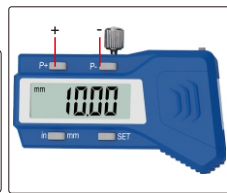

1mm<d<ØDmm
测量尺寸=读数+10mm

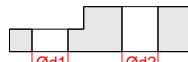

Ød1=Ød2, Ød1≠Ød2都可以测量

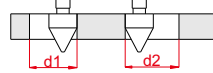

d1, d2>ØDmm时, 测量结果=读数+(d1+d2)/2

货号	量程	精度	c	ØD	L1	L2	L
151-006-11	10-150mm/0.4-6"	±0.05mm	16	10	32	65	236
151-008-11	10-200mm/0.4-8"	±0.07mm	16	10	32	65	306
151-012-11	10-300mm/0.4-12"	±0.09mm	16	10	32	65	396
151-020-11	20-500mm/0.8-20"	±0.09mm	24	20	48	88	686
151-040-11	30-1000mm/1.2-40"	±0.12mm	31	30	42	88	1242