

129-020-12

- ◆ 符合JJG通用卡尺国家计量检定规程
- ◆ 分度值:0.02mm/0.001"
- ◆ 带微调框
- ◆ 不锈钢尺身
- ◆ 刻度面镀暗铬

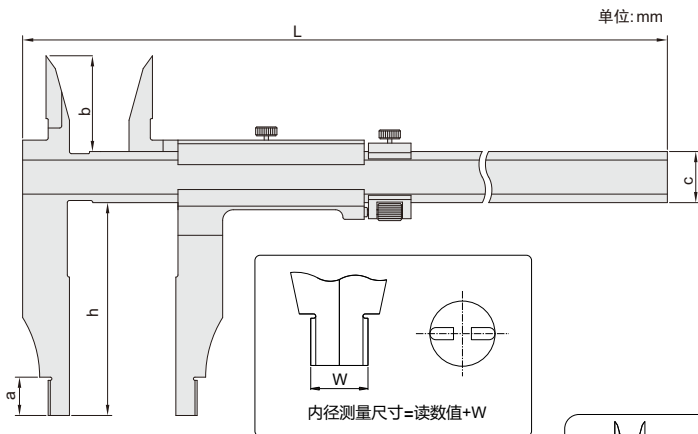

货号	量程	精度	a	b	c	h	w	L
129-020-11	0-500mm/0-20"	±0.05mm	18	45	24	100	20	670
129-020-12	0-500mm/0-20"	±0.06mm	18	45	24	150	20	670
129-024-11	0-600mm/0-24"	±0.06mm	18	45	24	100	20	770
129-040-11	0-1000mm/0-40"	±0.08mm	24	60	31	150	20	1230

