

# 硬质合金量面数显卡尺

## 116系列

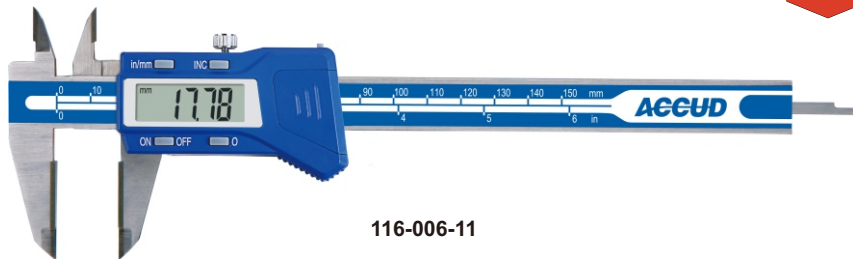

116-006-11

单位: mm

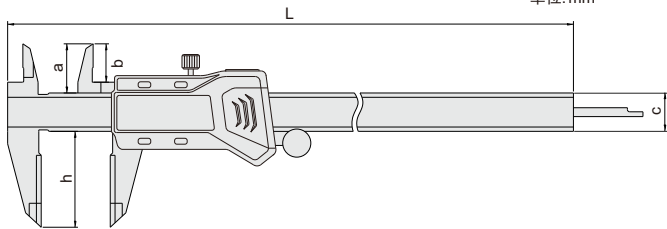

- ◆ 符合JJG通用卡尺国家计量检定规程
- ◆ 硬质合金量面, 耐磨性好
- ◆ 分辨率: 0.01mm/0.0005"
- ◆ 按键功能: 开/关机, 置零, 公/英制转换, 相对/绝对测量转换
- ◆ 带数据输出(数据线货号:100-03或100-04)
- ◆ 自动关机, 滑动开机
- ◆ 不锈钢尺身



硬质合金量面

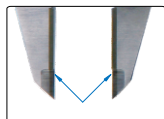

硬质合金量面

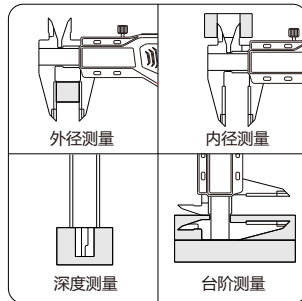

货号	量程	精度	a	b	c	h	L
116-006-11	0-150mm/0-6"	±0.03mm	21	16.5	16	40	236
116-008-11	0-200mm/0-8"	±0.03mm	24	19	16	50	286
116-012-11	0-300mm/0-12"	±0.03mm	26	20.5	16	60	400