

焊接规

973

◆ 不锈钢尺身



正面

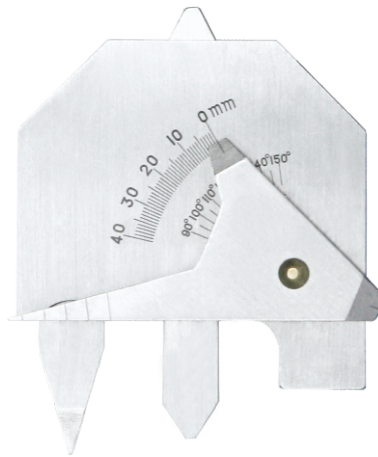

反面

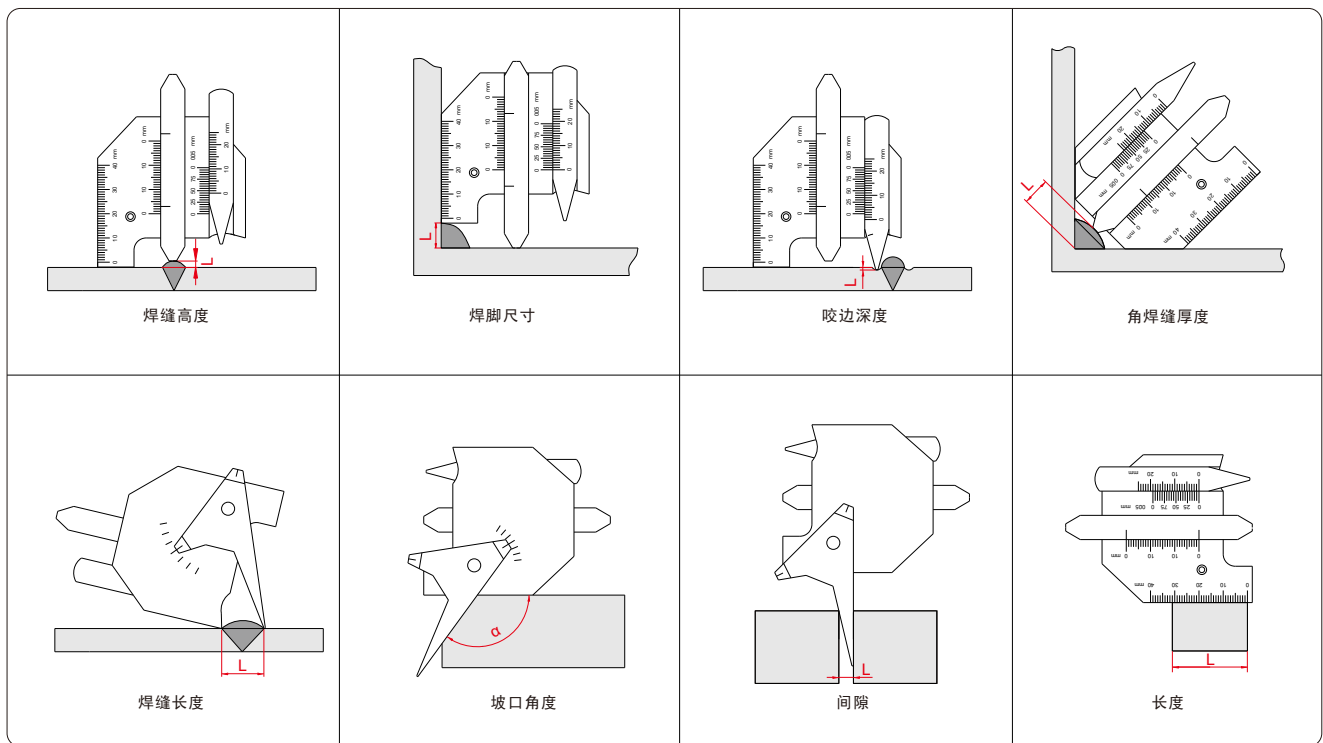

货号	测量项目	厚度范围	分度值	精度
973-014-01	焊缝高度	0 - 10mm	1mm	±0.5mm
	焊脚尺寸	0 - 14mm	1mm	±0.5mm
	咬边深度	0 - 5mm	0.05mm	±0.05mm
	角焊缝厚度	0 - 13mm	1mm	±0.5mm
	焊缝长度	0 - 40mm	1mm	±1mm
	坡口角度	90° - 150°	5°	±1°
	间隙	0.5 - 5mm	1mm	±0.5mm
	长度	0 - 40mm	1mm	±0.5mm

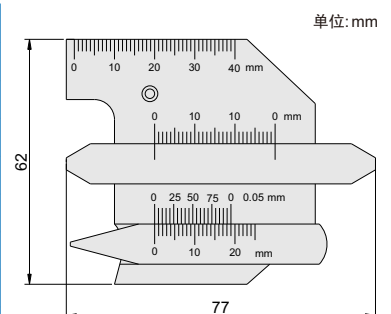

简易量具