

- ◆ 双面印字
- ◆ 不锈钢材质

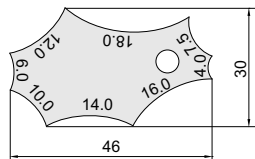

单位: mm

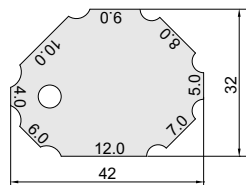

包装

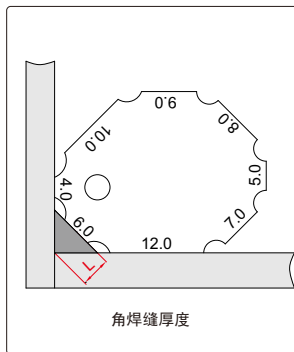

角焊缝厚度

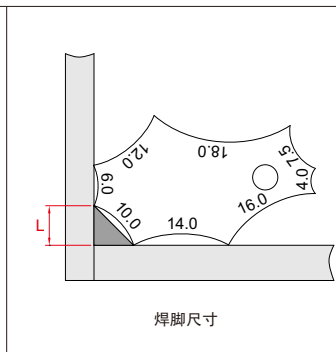

焊脚尺寸

简易量具

| 货号 | 角焊缝厚度 | 焊脚尺寸 | 精度 |
|------------|----------------------------|---------------------------------|--------|
| 972-012-01 | 4, 5, 6, 7, 8, 9, 10, 12mm | 4, 6, 7.5, 10, 12, 14, 16, 18mm | ±0.5mm |